

## VERSA AXS-FL Step

### VERSA AXS-FL Step

The **VERSA AXS-FL Step** is an electrical operated sliding step. In this step you find more than a decade of experience in step manufacturing. The slim design combines Aluminium profile with durable plastic end corners giving it a fresh look.

The step has a complete different construction compared to other products in the market. The closed sliding mechanism is built to keep dirt far away from the critical parts.

### AXS-FL Step Features:

- Build and designed with more than a decade experience.
- Optional Yellow LED Kit
- Closed design to keep dirt far away from critical sliding parts.
- Complete with opening movement obstacle detection.
- Step surface: Aluminium non-slip R10 / R11
- Supplied complete with wiring loom, integrated electronics, warning light for the driver, buzzer, magnetic touch less door switch and universal mounting brackets.

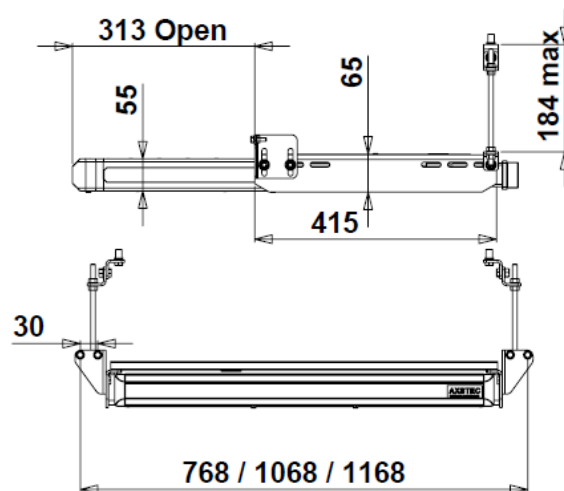
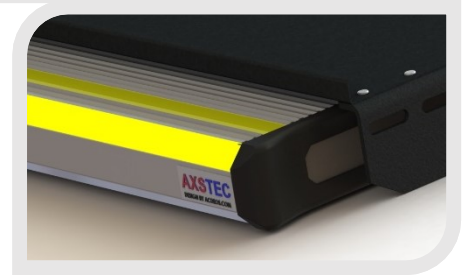
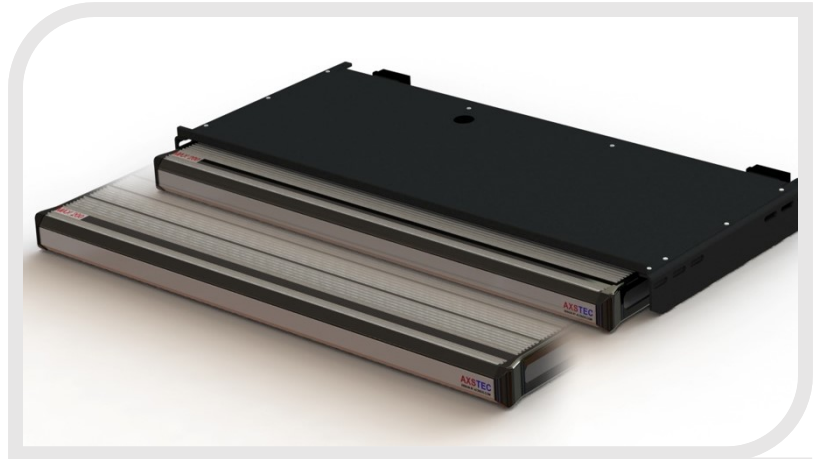

### AXS-FL Step specifications:

#### Dimensions:

Type	width	weight
AXS FL 600A	615 mm	25 Kg
AXS FL 900A	900 mm	28 Kg
AXS FL 1000A	1000 mm	31 Kg
Max Load:	200 Kg	

## VERSA AXS-FL Step